

© 1973 BY AMP INCORPORATED. ALL RIGHTS RESERVED. AMP PRODUCTS COVERED BY PATENTS AND/OR PATENTS PENDING.

Unpublished copy not to be reproduced without written permission of AMP Incorporated.

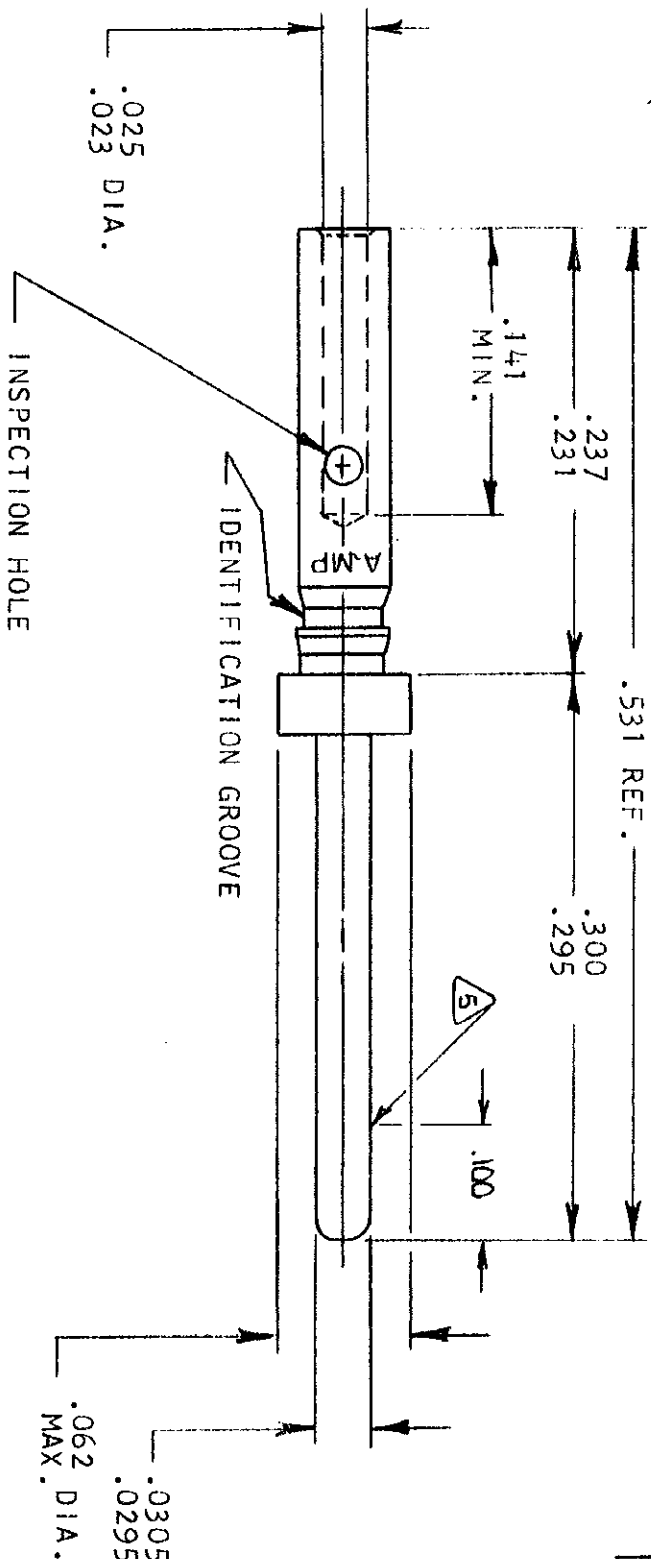

- 206495 - 3 1. AS SHOWN.
 2. PLATING : GOLD PER MIL-G-45204 OVER COPPER
- 206495 - 4 1. SAME AS - 3 EXCEPT:
 2. CONTACTS ON TAPE.

REVISIONS				
ZONE	LTR	DESCRIPTION	DATE	APPROVED
0		RELEASED WAS 5064-45 NO.	10/5/73	gms
A		REV PER ECN C-669	8/5/73	gms
B		CHANGED MAT'L ECN E779	11/28/76	gms
L		REV PER ECN J-985	9/23/78	gms

1. WIRE BARREL WILL ACCEPT # 26-28 AWG WIRE.
2. CRIMPING TOOL - USE MS 3198-1 WITH APPLICABLE POSITIONER.
3. CONTACT CONFORMS TO MIL-C-24308, SIZE 22 EXCEPT WIRE BARREL.
4. INSERTION / EXTRACTION TOOL - AMP P/N 91054-1
5. POINT OF PLATING THICKNESS MEASUREMENT.

WHEN ORDERING CONTACT ON TAPE, ORDER BY THE TAPE NUMBER PLUS THE PACKAGING CODE AS FOLLOWS:

1. FOR USE WITH AMP TAPETRONIC, PNEUMATIC TOOL -
 - A. 1000 PARTS TO A BOX ADD PACKAGING CODE: 1MBOX
2. FOR USE WITH 4/8 INDENT STRIPPER CRIMPER -
 - A. 1000 PARTS TO A REEL ADD PACKAGING CODE: 1MREEL
 - B. 5000 PARTS TO A REEL ADD PACKAGING CODE: 5MREEL

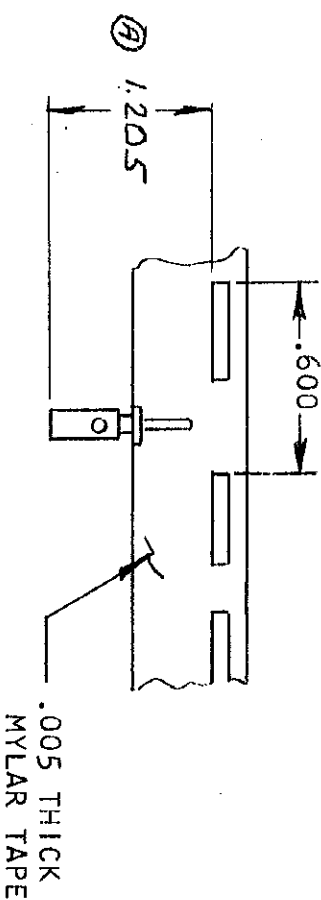

UNLESS OTHERWISE SPECIFIED DIMENSIONS ARE IN INCHES TOLERANCES ON: DECIMALS ± .005 ANGLES ± .1°

COPPER ALLOY PER QQ-C-530

CONTRACT NO. DR. 10/5/73
 APD 10/12/73
 D. Boar 10-18-73
 10-19-73

AMP AMP INCORPORATED HARRISBURG, PENNSYLVANIA
 NAME CONTACT, PIN SIZE 22D
 SIZE CODE IDENT. NO. NUMBER
 B 00779 206495
 SCALE 10:1 SHEET 1 OF 1